

TurboConnect™ EV Charge Station

Quick Start Guide



READ AND SAVE THESE INSTRUCTIONS



ETL and ETLc listed product per ANSI / UL standards UL2594, UL2231-2, UL1998
Certified to CAN / CSA standard C22.2 No. 280

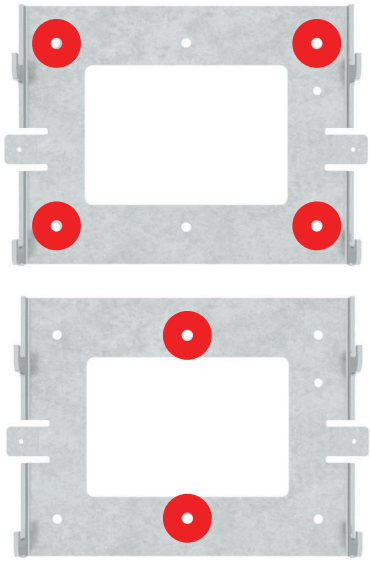

1



2

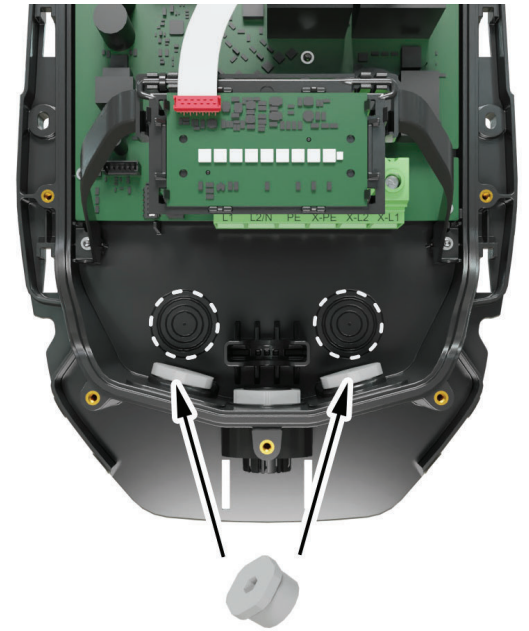

3

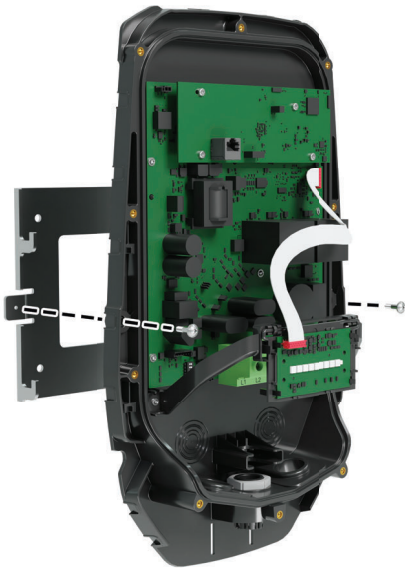

4



5



6

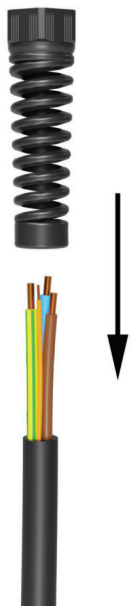

7

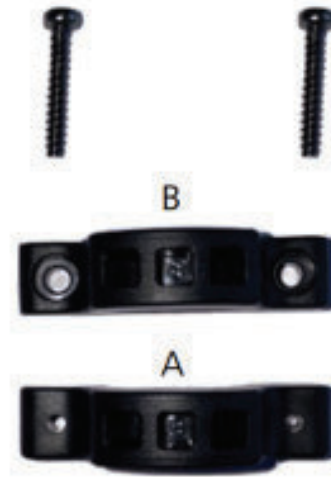

8

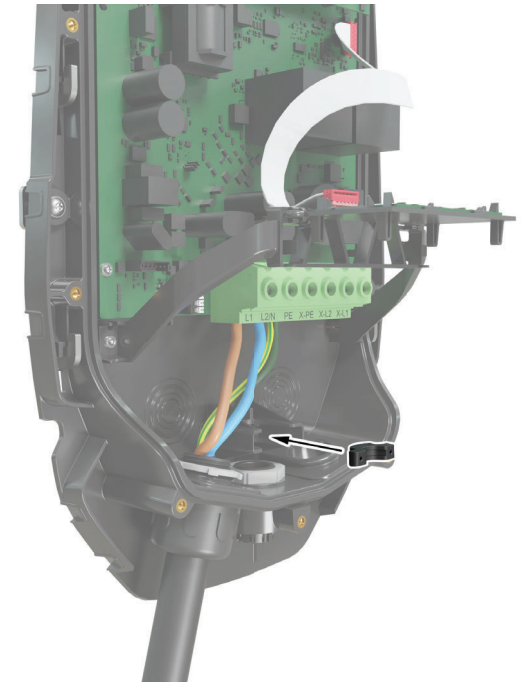

9

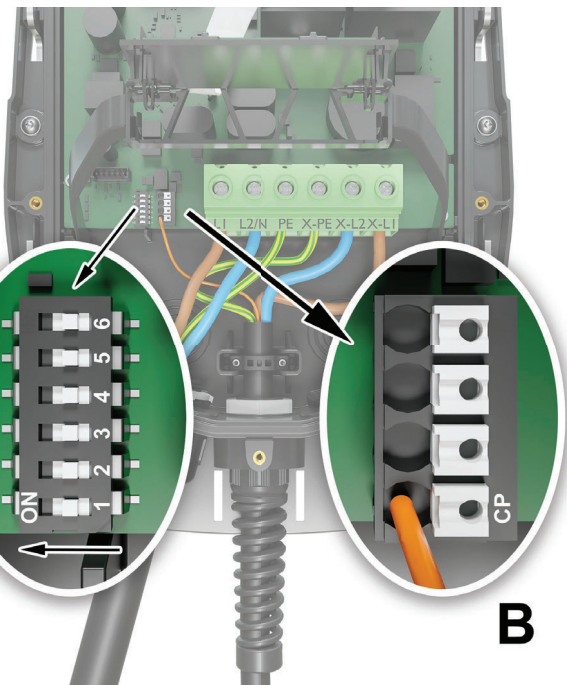

10

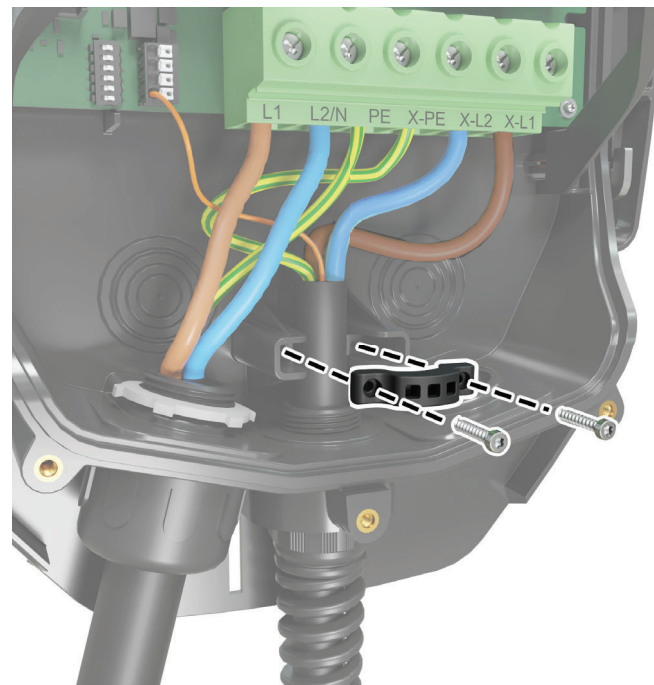

11

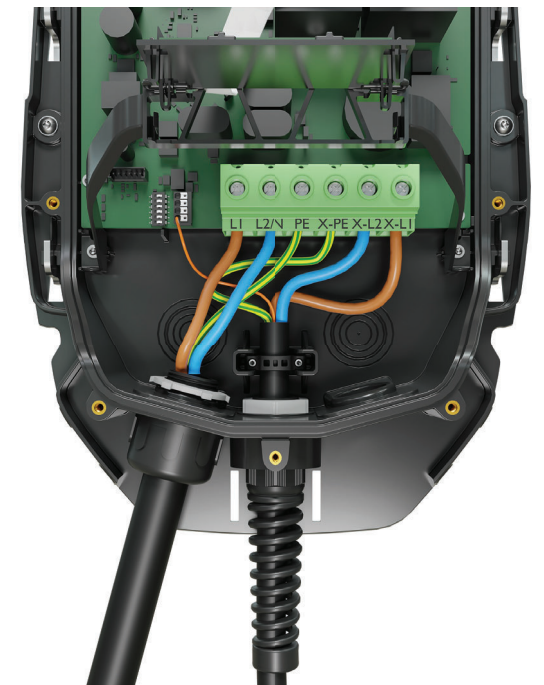

12



13



14

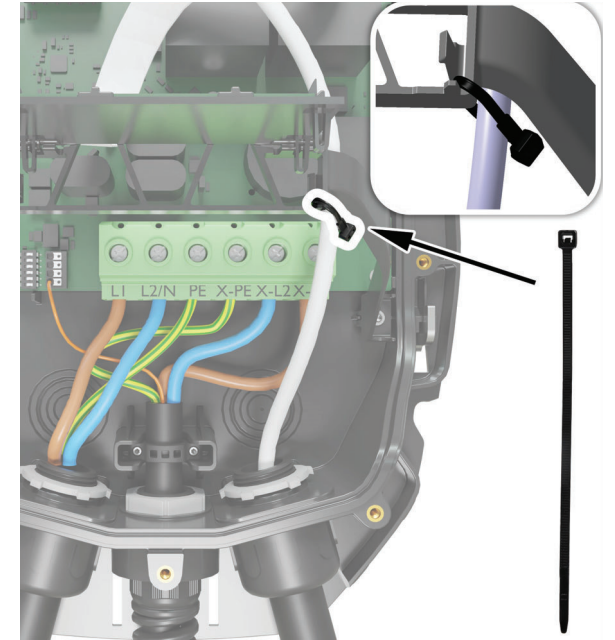

15

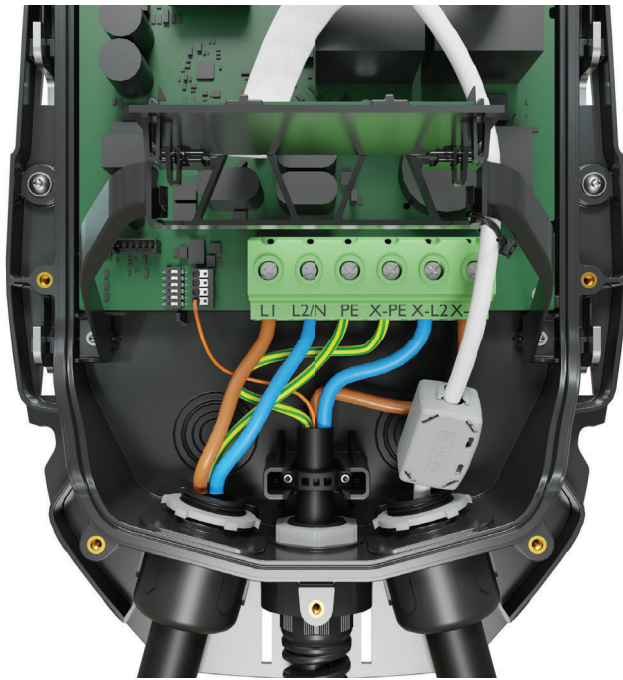

16

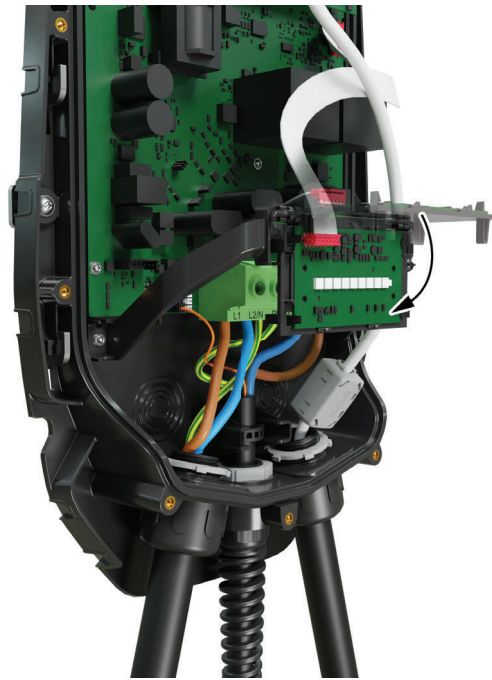

17

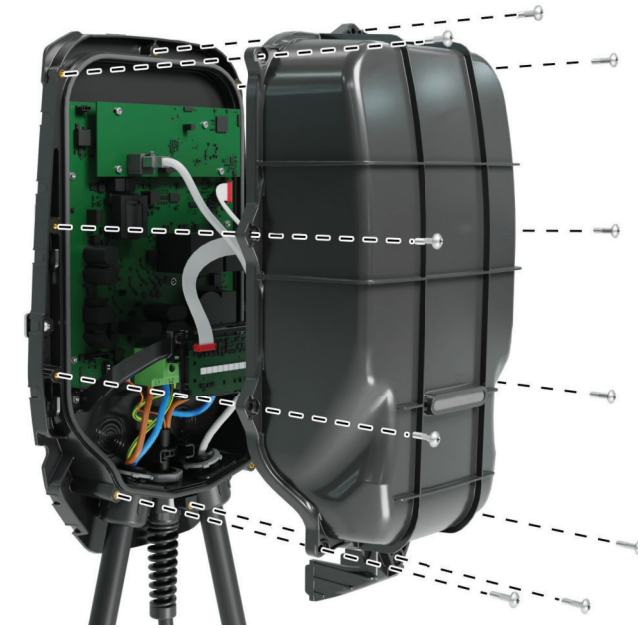

18



19



20

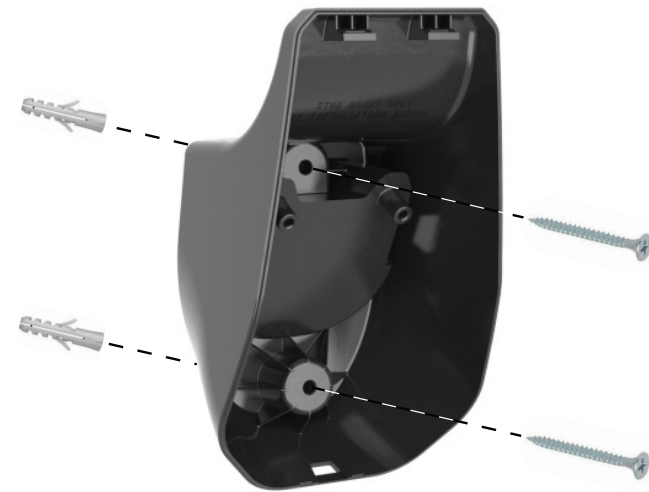

21

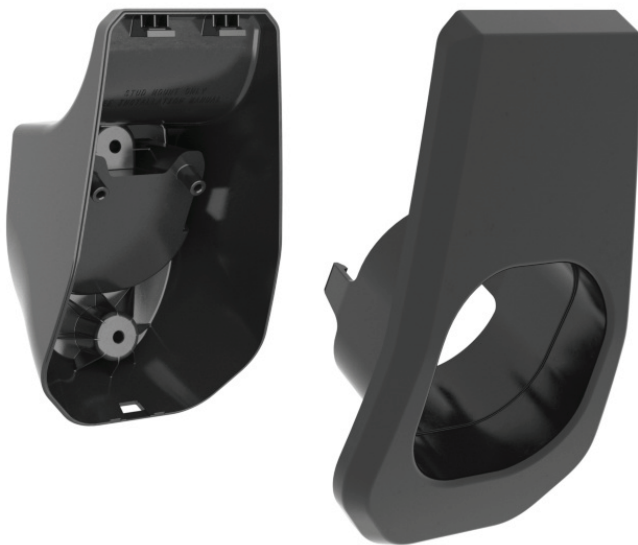

22



23



24

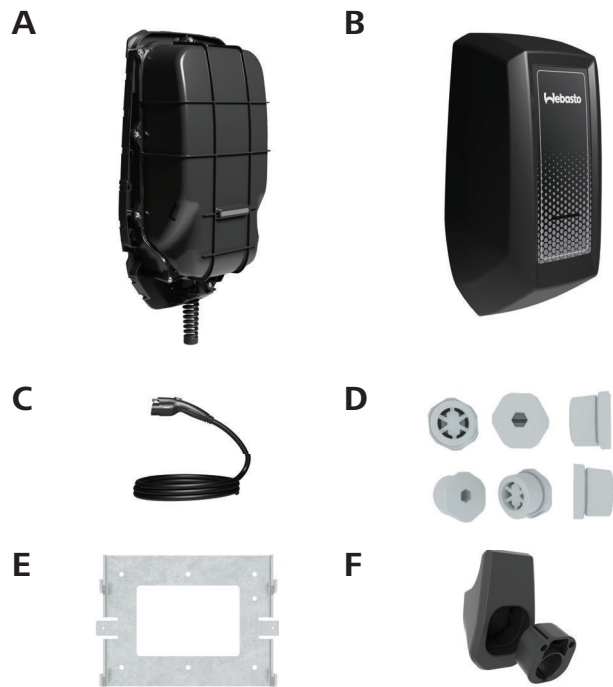

25

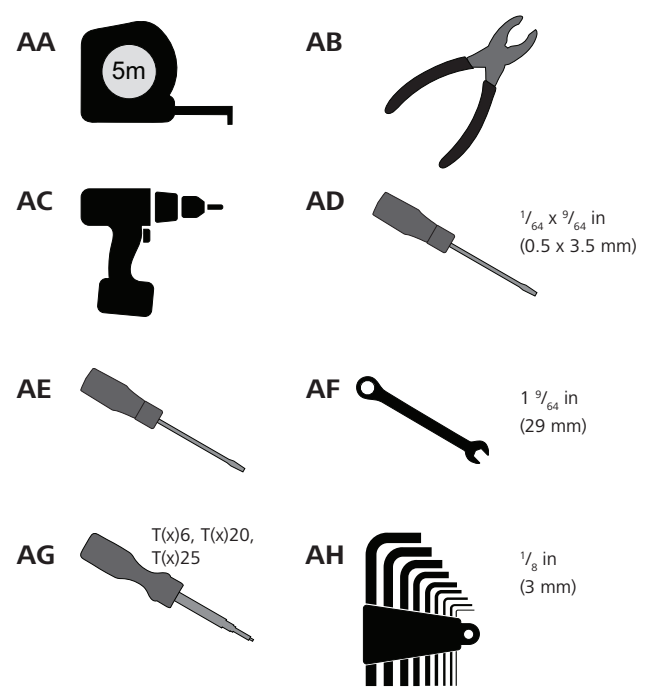
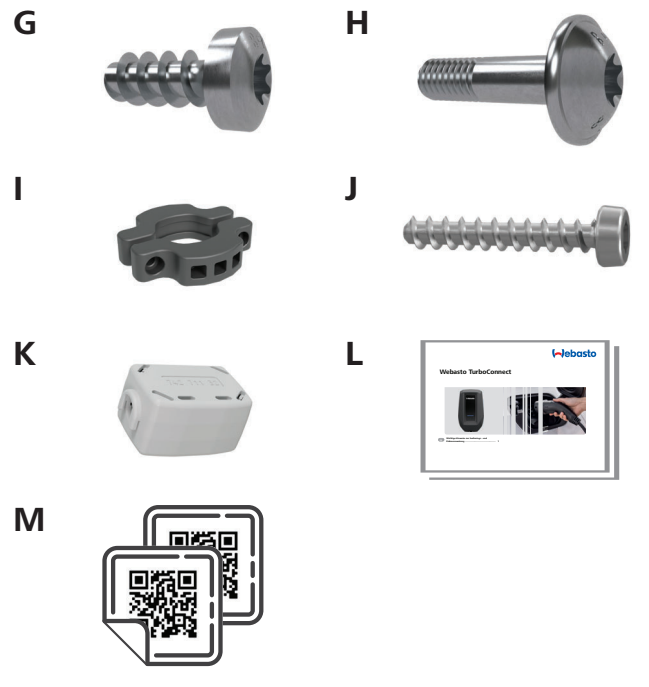

26

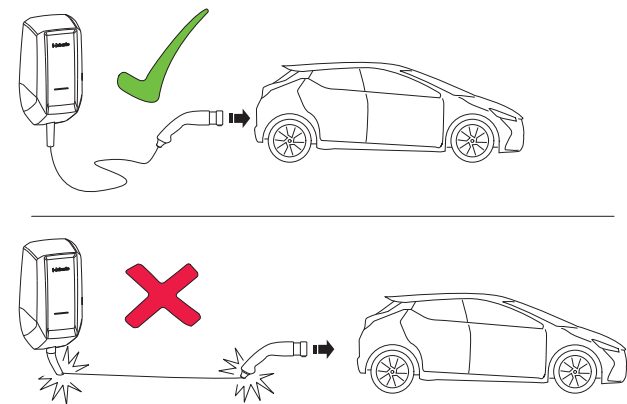

27

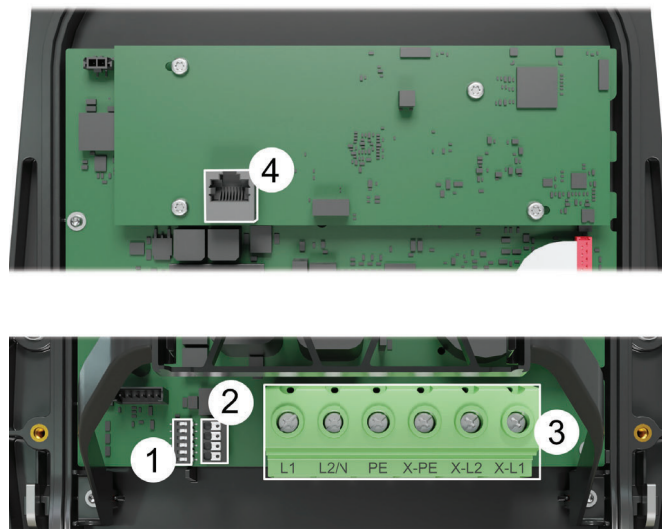

28

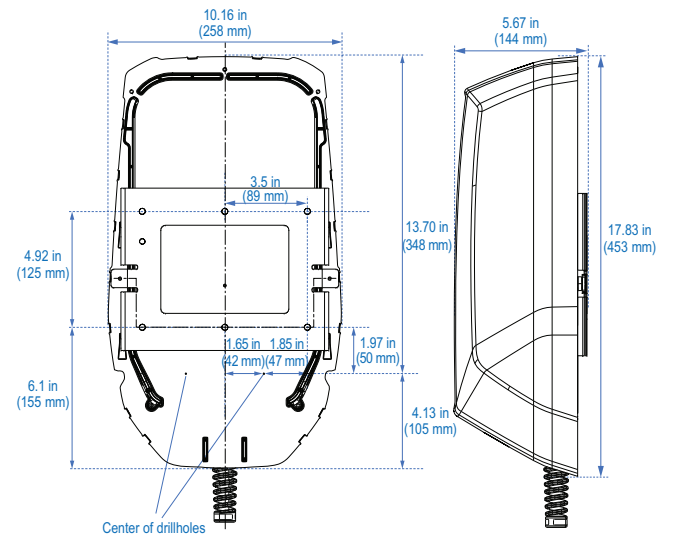

29

Table of Contents

1	Quick Start Guide for App Solutions	6	9	Dynamic Load management – Stand-alone mode (DLM)	17
2	General Information	7	10	Home Energy Management System (HEMS)	17
	2.1 Purpose of the document	7	11	Charge Station Dimensions	18
	2.2 Using this document	7	12	Settings	18
	2.3 Intended use	7	13	Operation	18
	2.4 Use of symbols and highlighting	7		13.1 LED and acoustic indicators	18
	2.5 Warranty and liability	7		13.2 Start Charging	18
	2.6 STATE OF CALIFORNIA PROPOSITION 65 WARNINGS	7		13.3 Stop Charging	18
	2.7 Software Licenses	7		13.4 Scan & Charge locking function	18
	2.8 Trademark and Copyright	7	14	Troubleshooting	19
3	Safety	7	15	Decommissioning the product	19
	3.1 General Information	7	16	Maintenance, cleaning, repair	20
	3.2 General Safety information	8		16.1 Maintenance	20
	3.3 Safety information for installation	8		16.2 Cleaning	20
	3.4 Safety information for electrical connection	9		16.3 Repair	20
	3.5 Safety information for initial start-up	9	17	Replacement of the charging cable	20
4	Unit description	9	18	Disposal	20
	4.1 Printing additional “Scan & Charge” QR codes	9	19	Declaration of Conformity	20
	4.2 Interface Descriptions	10	20	Federal Communications Commission (FCC) statement	20
5	Transportation and storage	10	21	Legal Notice	20
6	Scope of delivery	10	22	Technical data	21
7	Installation and electrical connection	10	23	Checklist for the installation of the Webasto charge station	23
	7.1 Required tools	10			
	7.2 Digital installation and user apps	10			
	7.3 Product location considerations	11			
	7.4 Criteria for the electrical connection	11			
	7.5 Installation	12			
	7.6 Apply Scan & Charge QR code	15			
	7.7 Preparing to set up the Charge Station	15			
	7.8 Initial start-up	15			
8	WebUI	16			
	8.1 Settings in the WebUI for DLM	16			
	8.2 Setting in the WebUI for HEMS	16			

1 Quick Start Guide for App Solutions



- ✓ The charge station must be installed by a qualified electrician.
- ↓ Download the Installation & Operation Manual. Scan the QR code or visit: www.evsolutions.com/ev-charging-product-resources



- ↓ Download the required Apps.
 - 1) For installation: Webasto Charger Setup.
 - 2) For operation: Webasto ChargeConnect.

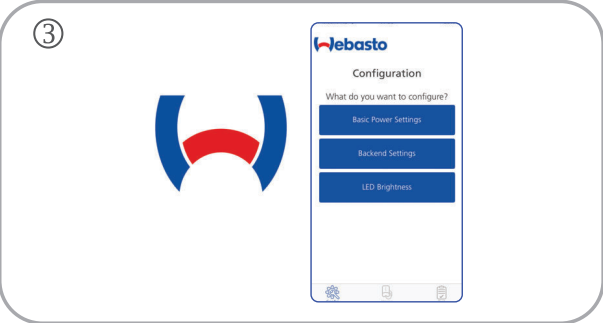

- ☞ Open the Webasto Charger Setup app and configure your charge station.

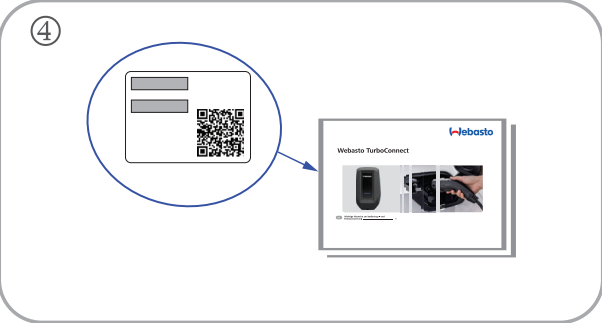

- 👁 Scan the Product Label QR code located in this manual or type in the wifi SSID and Key manually.



- ☞ Open the ChargeConnect app and follow the steps to connect the charge station to the ChargeConnect Cloud.



- ⚡ Plug in and enjoy exploring your station's capabilities.

2 General Information

2.1 Purpose of the document

This document is part of the product and contains information for electricians to carry out safe installation in accordance with local regulations, standards, and requirements. The updated version of the manual can be found on our website:

<https://www.evsolutions.com/ev-charging-product-resources>.



NOTE

In addition to this document, follow and comply with local regulations and standards relating to operation, installation, and environmental protection.

2.2 Using this document

- Read this document carefully before installing and starting the TurboConnect Charge Station.
- Keep these instructions ready to hand.
- Keep these instructions for future reference.



NOTE

We would draw your attention to the fact that, as part of a professional installation, an installation log should be drawn up by the installer. We also request that you fill in our checklist. See chapter 23, "Checklist for the installation of the Webasto charge station" on page 23.



NOTE

Individuals with a deficiency in their color vision require support in the allocation of all fault indicators.

2.3 Intended use

The TurboConnect Charge Station is designed for charging electric vehicles in accordance with SAE J1772, charge Level 2. In this mode, the charge station ensures that:

- The voltage is not applied before the vehicle has been properly connected.
- The maximum power is calibrated.
- The AC/DC converter is in the vehicle.

The charge station does not support ventilation, therefore if the EV (electrical vehicle) requests ventilation, the EVSE (electric vehicle supply equipment) will not energize the system.

2.4 Use of symbols and highlighting



DANGER: This signal word denotes a hazard with a high degree of risk which, if not avoided, will lead to death or serious injury.



WARNING: This signal word denotes a hazard with a moderate degree of risk which, if not avoided, may lead to minor or moderate injury.



CAUTION: This signal word denotes a hazard with a low degree of risk which, if not avoided, may lead to minor or moderate injury.



NOTE: This signal word denotes a Special Technical Feature or (if not observed) potential damage to the product.



Refers to separate documents which are enclosed or can be requested from Webasto.

2.5 Warranty and liability

Webasto shall not assume liability for defects or damage resulting from the installation and operating instructions being disregarded. This liability particularly applies for:

- Improper use.
- Repairs carried out by an electrician not contracted by Webasto.
- Use of non-original spare parts.
- Unauthorised conversion of the unit without permission from Webasto.
- Installation and commissioning by unqualified staff (not an electrician).
- Improper disposal after decommissioning.



WARNING

Installation and connection of the charge station must only be carried out by a qualified electrician.



The symbol of a bin with a line through means that the instructions in chapter 18, "Disposal" on page 20 must be followed.

2.6 STATE OF CALIFORNIA PROPOSITION 65 WARNINGS



WARNING

This product can expose you to chemicals including Styrene which is known to the State of California to cause cancer and Bisphenol A, which is known to the State of California to cause birth defects or other reproductive harm.

For more information go to:
www.P65Warnings.ca.gov.

2.7 Software Licenses

This product uses open-source software. Further information, such as disclaimers, written offers, and license information can be found via the integrated web server. The web server can be reached via the hotspot (<https://172.0.2.1/licensing.html>).

2.8 Trademark and Copyright

This product is protected by the copyright laws of the United States, Canada, and other countries. It may not be modified, reproduced, or distributed without the prior, express written consent of Webasto. Webasto and TurboConnect are U.S.-registered trademarks and cannot be used without the prior written consent of Webasto. Webasto Charging Systems, Inc. All rights reserved. ©2023

3 Safety

3.1 General Information

The TurboConnect Charge Station has been developed, produced, tested, and documented according to the relevant safety regulations and environmental requirements that apply to your geographical area.

You must only use the charge station in a technically faultless condition. Any malfunctions that adversely affect the safety of persons or the device must be immediately rectified by a qualified electrician in accordance with applicable regulations and warranty conditions. You are prohibited from modifying, changing, or manipulating the device.



NOTE

Signaling in your vehicle may differ from that described in this guide. Always read and observe the vehicle manufacturer's user manual.

3.2 General Safety information



DANGER

- You must comply with the locally applicable requirements regarding electrical installations, fire protection, safety regulations, and escape routes at the intended installation location.
- Hazardous voltages are present within the casing.
- The TurboConnect Charge Station does not have its own power ON/OFF switch. The protective devices (circuit breakers) installed in the power supply system are therefore also used to disconnect the power supply.
- Inspect the charge station for visual damage before installation and use. Do not use the charge station if it is damaged.
- Installation, electrical connection, and initial operation of the charge station must be carried out by a qualified electrician.
- The screw-mounted unit cover may only be removed by qualified electricians. Do not remove the unit cover whilst in operation.
- Do not remove markings, warning symbols, or the type plate from the charge station.
- The charging cable may only be replaced by qualified electricians and in accordance with the installation manual.
- You are prohibited from connecting other equipment / devices to the charge station than those for which the charge station was designed and intended.
- When not in use, store the charging cable in the designated holder and lock the charging coupling in the remote dock. Loosely wind the charging cable around the remote dock making sure the cable does not touch the floor.
- You must make sure that the charging cable and coupling cannot be driven over or trapped. Protect it from all other hazards.
- Immediately notify Customer Service if the charge station, charging cable, or charging coupling is damaged. Do not continue to use the charge station.

- Prevent the charging cable and coupling from contact with external heat sources, water, dirt, and chemicals.
- Switch off the power at the circuit breaker before installing or cleaning.
- Do not attach extension cables or adapters to the charging cable.
- Only remove the charging cable by pulling on the charging coupling.
- Never clean the charge station with a high-pressure cleaner or similar.
- Switch off the power supply before cleaning the charging sockets.
- The charging cable must not be subjected to any strain during use.
- You must make sure that no one has access to the charge station without reading this user manual first.
- Make sure that the charge station temperature is within its storage temperature limits when moving, transporting, or storing it.
- You are prohibited from pulling the charge station by its cable.
- The charge station must be connected directly to your home's mains connection; no plugs and sockets must be used.
- Do not put your fingers into the electric charger coupler.
- You may only operate the charge station after professional installation.
- When transporting the charge station, handle it with care. Do not subject it to strong force or impact, also do not pull, twist, tangle, drag, or step on the TurboConnect Charge Station, to prevent damaging it or any of its components.



NOTE

In addition to the safety instructions in this document, also observe further safety instructions in any other enclosed or online available documents. Please visit the webpage regularly to be updated on safety and operational instructions.

3.3 Safety information for installation



DANGER

- The instructions in this document must be followed for safe installation.
- Installation and connection of the charge station must only be carried out by a qualified electrician.
- You must comply with the locally applicable requirements regarding electrical installations, fire protection, safety regulations, and escape routes at the intended installation location.
- Only use the supplied installation material and other appropriate installation material.
- When the charge station is open, ESD (electrostatic discharge) precautions must be taken properly to avoid electrostatic discharge.
- When handling electrostatically sensitive boards, wear grounded antistatic wrist straps and properly observe ESD safety precautions. Wrist straps must only be used when mounting and connecting the loading unit. Wrist straps must never be worn on a live TurboConnect Charge Station.
- Electricians must be properly grounded during the installation of the TurboConnect Charge Station.
- Do not install the charge station in an explosion-sensitive area (Ex Zone).
- Install the charge station in such a way that the charging cable does not block any passageways.
- Do not install the charge station in areas subject to ammonia or air-containing ammonia.
- Do not install the charge station in a location where falling objects may damage it.
- The charge station is suitable for use indoors as well as outdoors.
- Do not install the charge station in the vicinity of water jets, such as car-wash installations, high-pressure cleaners, or garden hoses.
- Protect the charge station against damage caused by sub-zero temperatures, hail, or similar. We would like to refer you to our enclosure protection class NEMA 4. See chapter 22, "Technical data" on page 21.

- The charge station is suitable for use in areas without access restrictions.
- Protect the charge station from direct sunlight. The charging current may be reduced at high temperatures, or charging may be disabled completely. The operating temperature range is -40 °F to +122 °F (-40 °C to +50 °C).
- The installation location of the charge station should ensure that vehicles cannot inadvertently collide with it. Protective measures must be implemented if the possibility of damage cannot be ruled out.
- Do not put the charge station into operation if it has been damaged during installation; replacement will be required.
- Do not touch the electronic boards during the installation process.

3.4 Safety information for electrical connection



DANGER

- Installation and connection of the charge station must only be carried out by a qualified electrician.
- Each charge station must be protected with its own line circuit breaker.
- A qualified electrician must make sure that all electrical connections are de-energized before connecting the charge station to the power supply.
- A qualified electrician must make sure that a properly sized supply cable is used for the power connection.
- Do not leave the charge station unattended with an open cover.
- Change DIP-switch settings only with the power off.
- Register the use of the charge station with the power supply company and or utility as required.



**WARNING
GROUNDING INSTRUCTIONS**

The product must be connected to a grounded, metal, permanent wiring system, or an equipment grounding conductor must be run with the circuit conductors to the equipment grounding terminal or lead on the product. See chapter 7, "Installation and electrical connection" on page 10.

3.5 Safety information for initial start-up



WARNING

- The initial start-up of the charge station must be carried out by a qualified electrician.
- Before initial start-up, the qualified electrician must verify that the charge station has been connected correctly.
- Do not connect a vehicle during the initial start-up of the charge station.
- Before starting up the charge station, check the charging cable, charging coupling, and the charge station for visible damage. The charge station must not be started up if it is damaged or if the charging cable / charging coupling is damaged.

4 Unit description

This document describes the TurboConnect Charge Station. You can find the exact device details on the type plate of the charge station.

		Conforms to ANSI/UL Std. 2594 in conjunction with ANSI/UL Std. 2231-2 Cert. to CAN/CSA Std. C22.2 No. 280 Std. C22.2 No. 281.2	Input / Output Tension d'entrée / sortie Alimentación / Salida
Webasto Charging Systems Inc. 1333 Mayflower Avenue Monrovia, CA 91016		5019177	Voltage / Voltage (c.a.) Voltaje 208/240 V (AC)
TurboConnect Type 4 Enclosure		Contains FCC ID: Z64-WL18SBMOD Contains IC ID: 451I-WL18SBMOD	Current / Courant / Intensidad 48 Amps
Ventilation Not Required / Aucune ventilation requise / No requiere ventilación			Freq. / Fréq. / Frec. 60 Hz
For use with Electric Vehicles / Pour utilisation avec des véhicules électriques / Para uso con vehículos eléctricos			Nr. of phases / Nombre de phases / Nr de fases 1
Read owner's manual before operating / Vous lisez le manuel de l'utilisateur avant d'utiliser / Lea el manual de usuario antes del uso.			Operating Temp / température de fonctionnement / Temperatura de operación -40 to +50 [°C]
Use Copper or Aluminum Conductors / Utiliser des conducteurs en aluminium ou en cuivre / Utilizar conductores de cobre o aluminio			Made in Germany Fabriqué en Allemagne Fabricado en Alemania YYYY-MM
Customer Service Phone Nr: 888-833-2148 Serial No.: XXXXXXXXXXXXXXXXXX Material: YYYYYYYY EC: ZZZ			

4.1 Printing additional "Scan & Charge" QR codes

In the scope of delivery (SOD), you will find "Scan & Charge" QR stickers. If the QR code used for your charge station is no longer readable, you can generate a new copy using the product details and the serial number of your charge station.

1. Click on the following URL to add the QR code generator extension to your Chrome browser.
<https://chrome.google.com/webstore/detail/qr-codegenerator/afpbjgbdimpioenaedcjkgaiggcdpp>
2. In your Chrome browser, click the new icon at the top right.
3. Enter the details of your charge station in the following format:
PROD:[Part number];SERIAL:[Serial number]
Example: PROD:5112300C;SERIAL:TURBOCON-WS123456
This information can be found on the type plate on your charge station.

4. Click Download to download the generated PNG file.
5. You can optionally insert the PNG file into a Word document.
6. Print the downloaded PNG file or Word document.

4.2 Interface Descriptions

4.2.1 Hardware interfaces

The Charge Station contains various hardware interfaces (see Fig. 28). Each interface serves another purpose. The following table shows detailed descriptions of each interface.

1	DIP switches (1 to 6)
2	Connector for CP
3	Power supply terminal blocks for grid input and charging cable output wires
4	RJ 45 port

4.2.1.1 Ethernet / RJ45 / LAN

To connect the TurboConnect Charge Station to a network, use an ethernet cable with an RJ45 jack to plug into the RJ45 port on the electronic board. You can also configure and control the charge station using this connection. The control system requires a connection to the backend or a local energy management system. Webasto recommends a CAT7 network cable, but CAT6a is sufficient.

Follow the installation instructions in chapter 7.5.8, "Connecting the ethernet cable (optional)" on page 14 for connecting the TurboConnect Charge Station via an ethernet interface. If you want to implement multiple functions via the LAN interface, such as ModBus and an internet connection, a DHCP network switch or router can be connected to the incoming circuit of the building wiring system.

4.2.1.2 Modbus TCP

The TurboConnect Charge Station is set up for the use of an extended energy management system (EMS) via a higher-level electricity meter for multiple use cases, such as cluster load management, or it can be connected to a Smart Meter for circuit load balancing. These functions can be configured through the web-config interface in the setting section.

4.2.1.3 Control Pilot (CP)

The charging cable comes with power supply lines and a data line which is known as CP (control pilot) line (orange wire).

4.2.1.4 Power supply terminals

The terminal connectors for the grid wiring are marked L1, L2/N, PE on the left side of the terminal block.

The terminal connectors for the charging cable are marked X-PE, X-L2/X-N, X-L1 and are located on the right side of the terminal block. See Fig. 28, position mark 3.

4.2.2 Wi-Fi

After completing the start process of the charge station, you can connect a Wi-Fi-enabled computer or mobile device to the charge station hotspot (standard configuration via Webasto Charger Setup app). The Wi-Fi hotspot can be used to configure the charge station (Webasto Charger Setup app). You can connect the TurboConnect Charge Station to a Wi-Fi router to establish an internet connection (configuration via Webasto Charger Setup app or WebUI).

5 Transportation and storage

Observe the ambient temperature for storage during transportation. See chapter 22, "Technical data" on page 21. Transport the charge station only when suitably packaged.

6 Scope of delivery

Scope of delivery for the charge station. See Fig. 25.

A	Main unit
B	Design cover
C	Charging cable with coupler
D	Blind plugs
E	Wall mount bracket
F	Dock rear holder, dock front cover & dock insert
G	Screws 1 ³ / ₆₄ x 1 ⁵ / ₃₂ inch (5 x 12 mm)
H	Screws 5/32 x 5/8 inch (4 x 16 mm)
I	Cable fixation
J	Screws 5/32 x 1/2 inch (4 x 13 mm)
K	Ferrite kit (incl. ferrite & cable tie)
L	Manual
M	"Scan & Charge" QR codes

7 Installation and electrical connection

Observe the safety information. See chapter 3, "Safety" on page 7. Download the latest manual from the website for updated instructions.

7.1 Required tools

To install the TurboConnect Charge Station, you need the tools in the following table. See also Fig. 26.

AA	Measuring tape
----	----------------

AB	Pliers
AC	Power drill
AD	Slot-head screwdriver
AE	Crosshead screwdriver
AF	Combination wrench (1 ⁹ / ₆₄ inch (29 mm))
AG	Torx screwdrivers (T6 (included), T20, and T25)
AH	Allen wrench (¹ / ₈ inch (3 mm))

7.2 Digital installation and user apps



DANGER

You must observe the safety information. See chapter 3, "Safety" on page 7.

Webasto Charger Setup app (for installation)

To download this app:

- ▶ scan the QR code below or



- ▶ go to:
<https://apps.apple.com/> (Apple App Store) or
<https://play.google.com/> (Google Play Store) as appropriate.

Webasto ChargeConnect app (for operation)

To download this app:

- ▶ scan the QR code below or



- ▶ go to:
<https://apps.apple.com/> (Apple App Store) or
<https://play.google.com/> (Google Play Store) as appropriate.



CAUTION

The TurboConnect Charge Station safety concept is based on a power supply system that is earthed at all times, which must always be ensured by an electrician during installation.

7.3 Product location considerations

The following points must be considered when selecting the installation location for the TurboConnect Charge Station and the external holster:

- It is recommended to mount the Charge Station at least 35.4 inches (900 mm) above floor level. If you are installing more than one Charge Station, then you must minimally leave 7.9 inches (200 mm) in between. The mounting surface must be solid and strong.
- The mounting surface must be completely flat (about 0.04 inch (max. 1 mm) difference between the individual mounting points) and with a vertical orientation.
- The mounting surface must not contain any flammable substances.
- The cable length used from the charge station to the vehicle shall be as short as possible. The charging cable may never be under tension strain in any situation (see Fig. 27).
- There shall be no (obvious) risk of driving over the charging cable.
- There shall be no additional electrical wires and connections from the infrastructure.
- The charge station may not be an obstacle to pavements and escape routes.
- An installation location protected against direct sunlight, rain, or other environmental impact is required for optimum and fault-free operation.
- The usual parked position of the vehicle, taking account of the charging plug's position on it.
- Consideration of local building- and fire protection regulations.
- If the charge station is to be connected, then make sure to have fault-free Wi-Fi reception.
- Whenever possible, mount the Charge Station protected from direct sunlight or rainfall.

7.4 Criteria for the electrical connection

The TurboConnect Charge Station type plate indicates the maximum charging current that you can configure. The type plate is located on the front cover of the unit. The power availability at the service connection determines the maximum permitted charging current. A qualified electrician must make the necessary settings in the configuration. They must also verify the prerequisites for connection. The installation must comply with the nationally applicable regulations of authorities and power supply companies, such

as the registration of the installation of a charge station. All protective devices specified must be designed in such a way that every power supply pole of the TurboConnect Charge Station is disconnected if a fault occurs. The selection and installation of the protective device must comply with national installation regulations and standards.

 **NOTE**
Do not install a GFCI (Ground Fault Circuit Interrupter).

 **NOTE**
Install a dedicated circuit with sufficient service capability for the chosen power setting of the Charge Station. Additionally, upgrade your panel with a dedicated circuit breaker. Follow your regional regulations and electric code.

 **NOTE**
The current value of the selected protective device must not fall below the current value specified on the type plate for the charge station or the value set using the DIP switch. See chapter 7.4.1, "DIP switch settings" on page 11.

The installation requirements for the charge station must be checked by a qualified electrician before starting connection works. Comply with the nationally applicable regulations of the authorities, utilities, and power supply companies, such as installation registration of a charge station.

 **NOTE**
In some cases, regions, and states current limits may apply. The local connection requirements must be observed.

All protective devices specified below must be designed such that the charge station is disconnected from the grid in the case of a fault. You must meet national installation regulations and standards when selecting the protective device.

7.4.1 DIP switch settings

The maximum charging current is factory set and is indicated on the type plate of the charge station. The maximum charging current can be adapted to the value of the circuit breaker fitted during installation using DIP switches.

 **Danger**
High voltages
The danger of fatal electric shock.
Ensure safe isolation from the power supply.

The DIP switches are located in the Charge Station installation area (see Fig. 28 – view 1). The Charge Station has six switches numbered from 1-6 (see Fig. 10 – interface A). Each switch configures a specific setting. The dip-switch settings are listed in the table below.

 **CAUTION**
Indicated minimum circuit breaker ratings in Table 1, "DIP switches 1–4" on page 11 are recommendations by Webasto. Follow codes and regulations for circuit breaker dimensioning and current settings.

D1	D2	D3	D4	Current Limit Charge Station	Circuit Breaker Current Rating
0	0	0	0	Invalid	–
0	1	0	1	12A	15A
0	1	1	1	16A	20A
1	0	0	0	20A	25A
1	0	0	1	24A	30A
1	0	1	1	32A	40A
1	1	0	1	40A	50A
1	1	1	1	48A	60A

Table 1: DIP switches 1–4

D5	[A]	
0	D1–D4	Default
1	0A	Invalid

Table 2: DIP switch 5

D6	Mains Voltage	
0	208V	Industrial split phase 120°
1	240V	Residual split phase 180°

Table 3: DIP switch 6

7.4.2 Power supply isolation device

The charge station does not have its own power ON/OFF switch. The protective devices installed in the power supply system are therefore also used to disconnect the Charge Station.

7.4.3 Dimensioning the lead's cross-section

A qualified electrician must determine the cross section / wire gauge size of the input conductor in accordance with

all applicable state, local, and national electrical codes, and standards. See chapter 4, "Unit description" on page 9. The input conductor cross-section of the wire depends on multiple factors, e.g.:

- The maximum power available from the service connection.
- The cable length.

7.5 Installation

7.5.1 Step-by-step installation

Before starting the step-by-step installation process, please make sure that the panel, circuit, and circuit breaker are already installed and checked for compatibility. Make sure that the circuit is disconnected from electricity during the installation process.



NOTE

Carefully read the complete manual before starting the installation.
Have the necessary equipment and tools ready.



Danger High voltages

The danger of fatal electric shock. Make sure to disconnect the charge station from the electric circuit during the installation.

7.5.2 Installing the mounting bracket

Decide on the mounting position for the Charge Station. Please keep in mind the following restrictions:

- Consider reaching the vehicle charging port without straining the charging cable.
- The external coupler holder can be positioned wherever it fits best in reachable distance.
- Keep in mind where the grid wires are located (rear-facing or floor-facing, conduit position, hardwired cut-outs).
- Optional:
When using an ethernet cable for hard-wired backend connection, keep in mind where the ethernet wire is located (rear-facing or floor-facing). It is not allowed to use the same conduit for high power grid wires and ethernet communicating wires.

See chapter 11, "Charge Station Dimensions" on page 18, for product dimensions and drilling template to determine the installation position.



NOTE

Power lines and communication lines need separate feedings. Follow the local standard and regulations.

The following paragraphs offer alternative installation paths:

- Chapter 7.5.2.1, "Attach the bracket to a wall" on page 12.
- Chapter 7.5.2.2, "Attach the bracket to a pole" on page 12.

7.5.2.1 Attach the bracket to a wall



NOTE

It is recommended to install the wall mount bracket in such a way that the lower end of the bracket is at least 40.5 inches (1030 mm) off the floor.



NOTE

You must make sure that the drill holes are at least 4 inches (100 mm) deep.



WARNING

Check if the supplied screws and dowels are appropriate for use with your wall. Make sure to use appropriate mounting means to guarantee that the wall and wall bracket can securely hold the charge station and all loads that will be applied to it.

To wall-mount the bracket:

1. Remove the mounting bracket from its box (see Fig. 1).
2. Mark the four drill hole positions on the wall using the bracket as a template.
3. Drill four drill holes ($\frac{5}{16}$ inch / 8 mm) in the marked positions.
4. Push the four wall plugs ($(\frac{5}{16} \times 2)$ inch) (8 x 50 mm)) firmly into the drill holes.
5. Secure the bracket using a T25 screwdriver and four screws ($(\frac{1}{4} \times 3\frac{1}{2})$ inch) (6 x 90 mm).

7.5.2.2 Attach the bracket to a pole



NOTE

You must install the wall mount bracket in such a way that the lower end of the bracket is at least 40.5 inches (1030 mm) off the floor.



WARNING

The supplied installation material is intended for mounting the charge station on a masonry or concrete wall. For installation on a stand, the mounting material could differ from the used stand. The included wall bracket works for all installations. Specific screws or other mounting material for stands are not in the scope of delivery.

To pole-mount the bracket:

1. Remove the mounting bracket from its box.
2. Mark the two drill hole positions on the pole.
3. Drill two holes ($\frac{5}{16}$ inch / 8 mm) in the marked positions.
4. Push the two wall plugs ($(\frac{5}{16} \times 2)$ inch) (8 x 50 mm)) firmly into the drill holes.
5. Pole-mount the bracket using a T25 screwdriver and two screws ($(\frac{1}{4} \times 3\frac{1}{2})$ inch) (6 x 90 mm)).

7.5.3 Removing the front cover & bend relief

Start removing the attached bend relief by hand (spiral attachment). Remove the three screws ($\frac{5}{32} \times \frac{5}{8}$ inch (4 x 16 mm)) from the front cover using a T20 screwdriver, as shown in Fig. 2.

Keep the bend relief, front cover, and screws aside for later use.

7.5.4 Installing the blind plugs and conduit fitting

1. Choose the appropriate conduit, in accordance with all applicable state, local, and national electrical codes, and standards. Make sure that you use installation equipment that meets the ingress protection class of the system (NEMA 4).
2. Decide on using the optional Ethernet cable.
3. Choose the grid cable and Ethernet cable (optional) entry positions, and then mount the conduit fitting in the required position. There are:
 - Two floor-facing entry positions at the bottom of the enclosure (preformed $\frac{3}{4}$ " NPT (National Pipe Thread)), and
 - Two rear-facing entry positions at the back of the enclosure (drill templates for $\frac{3}{4}$ " to 1" conduit cutouts). See superimposed markings in Fig. 3.
 - After drilling the required holes, remove all particles. Use appropriate material and equipment to meet ingress protection requirements (NEMA 4).
4. All not used entry interfaces must be covered with blind plugs to meet ingress protection NEMA 4.

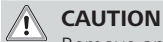
**CAUTION**

Remove any waste, such as insulation trimmings, from the connection area.

**CAUTION**

For rear-facing installations, use an appropriate cord grip that meets the NEMA 4 standard.
For floor-facing installations of the grid cable, use a ¾" NPT cord grip. (NPT = American National Standard Pipe Thread standards, also known as national pipe thread, that meets the NEMA 4 standard).

**CAUTION**

- When opting for rear-facing positions, you must make sure that you drill the conduit entry hole very carefully to prevent damage to internal components. Any damage caused is entirely at your risk. If parts of the charge station, except the removed cutout area, are damaged during installation, you must not use the product after it has been damaged.
- Mount the conduit in accordance with all applicable state, local, and national electrical codes, and standards. If necessary, use a flexible liquid-tight conduit to facilitate mounting the charge station onto the wall.
- Using an S8 hex Allen wrench or a 9/64 in (29 mm) wrench, mount the enclosed blind plugs in any unused cable entry positions (torque setting: 5 Nm / 44,3 in-lbs.). After mounting the plugs, visually verify the tight assembly.

**NOTE**

You can use flexible or regular conduits for installing your charge station.

7.5.5 Mounting the rear housing on the bracket

After the decision and preparation of the grid entry position, you can now mount the rear housing on the wall bracket (see Fig. 4).

- Use the hooks on the wall bracket and slide in the rear housing.
- Now check the final position and use a Torx T20 screwdriver and two screws 13/64 x 15/32 inch (5 x 12 mm) to mount the rear housing onto the mount bracket (torque: 4Nm / 35.4 in-lbs.).

**NOTE**

While positioning the rear housing, especially for rear-facing installations, make sure that the grid wires and the optional Ethernet cable fit through the designated entry points.

7.5.6 Connecting the grid wires

To connect the grid wires to the Charge Station:

- Remove any debris, such as insulation trimmings, from the connection area.
- Make sure and verify that the lead is tension-free and that you have taken measures to protect against the power being switched on.
- Lift the HMI as shown in Fig. 5 to have better access to the terminals. (Keep it up until directed otherwise).
- If you are using a rigid lead, then bend each of the wires, while observing minimum bend radiuses, so that you can connect the wires to the terminals without any major mechanical stress.
- Connect the power cables by properly pushing them into the terminals (L1, L2/N, and PE) as shown in Fig. 6 then tighten the screws using a crosshead screwdriver (Type PZ2). When tightening the screws, apply the following torques depending on the conductor cross sections:
 - lead cross-section $\leq 25\text{mm}^2$ / AWG number 4 and higher: 2.5 Nm / 22.2 in-lbs.
 - lead cross-section $> 25\text{mm}^2$ / AWG number 4 and lower: 4.5 Nm / 39.9 in-lbs.
- See also chapter 4.2.1.4, "Power supply terminals" on page 10.
- Finally, re-check that you have fastened all wires securely in their respective terminals.

**CAUTION**

Do not overtighten the terminal's screws.

**WARNING****240V line-to-line installation:**

The input connection must be selected with DIP switch 6 installed in a 1-phase system using a line-to-line connection. See chapter 7.4.1, "DIP switch settings" on page 11. The voltage between Line 1 and Line 2 is 240 V AC; between Line 1 and the ground is 120 V AC; between Line 2 and the ground is 120 V AC.

208V line-to-line installation:

The input connection must be selected with DIP Switch 6 installed in a 1-phase system using a line-to-line connection. See chapter 7.4.1, "DIP switch settings" on page 11. The voltage between Line 1 and Line 2 is 208 V AC, between Line 1 and the ground is 104 V AC, and between Line 2 and the ground is 104 V AC.

**WARNING**

Make sure that the lead is tension-free, and that measures have been taken to prevent the unit from being switched on.

**WARNING**

If you are using a rigid lead, then bend the individual wires, while observing the minimum bend radiuses to connect the wires to the terminals without significant mechanical stress.

**WARNING**

Verify that the ferrules have been placed in the terminals correctly and that the terminal screws have been tightened correctly after.

7.5.7 Install charging cable

- Take the charging cable and slide on the bend relief. See Fig. 7.
- Insert the cable clamp (Fig. 8 – part A) into the slot on the enclosure base as shown in Fig. 9.
Keep in mind the cable clamp assembly consists of two plastic parts and two screws as shown in Fig. 8. The lower half (A) has smaller holes so that the screws can drill in.
- Insert the charging cable through the cable gland in the center of the enclosure.
- Connect the charging cable wires by properly pushing them into the terminals (X-L1, X-L2, and X-PE) as shown in Fig. 12 then tighten the screws using a crosshead screwdriver with a torque of 22.2 in-lbs. (2.5 Nm) (Type PZ2).

5. Connect the wire of the communications protocol (CP) wire (orange) to the CP snap-in terminal on the left of the power input connector as shown in Fig. 10 – interface B.
6. Insert the second cable clamp (Fig. 8 – part B) into the slot as shown in Fig. 11. Make sure that the charging cable isolation jacket is at least 0.5 inch / 1.3 cm above the clamp. Fasten the clamp with the screws (($\frac{5}{32} \times \frac{3}{64}$ inch) (4 x 13 mm)) supplied using a Torx T6 screwdriver and apply a torque setting of 0.4 Nm / 3.5 in-lbs (see Fig. 12).
7. Use a $1 \frac{9}{64}$ inch (29 mm) wrench (torque: 4 Nm / 35.4 in-lbs.) to fasten the bend relief.

**CAUTION**

The two small, near semi-circular, plastic parts of the strain relief clamp differ slightly. The lower part has smaller screw holes in which the screws grip. The upper part has larger screw holes and recesses in which the screws can move freely.

**CAUTION**

Make sure that the enclosure type rating (NEMA 4) is maintained after the conduit and the charging cable have been installed. Verify that conduit entry accessories, such as blind plugs and cable glands, etc. have been fitted properly. This also applies to sealing rings. Do not overtighten the terminal screws.

The strain relief clamp is screwed to the charging cable and fixed in a holder in the housing. This provides strain relief for the charging cable. The charging cable is sealed with an additional cable gland with bend protection (middle cable bushing at the bottom of the charge station).

**WARNING**

Make sure that the lead is tension-free, and that measures have been taken to prevent the unit from being switched on.

**WARNING**

Verify that the ferrules have been placed in the terminals correctly and that the terminal screws have been tightened correctly after.

7.5.8 Connecting the ethernet cable (optional)

The TurboConnect Charge Station can be connected by wire (LAN) to the network infrastructure with an ethernet cable

using the RJ45 jack interface on the electronic boards (location is shown in Fig. 13). The charge station can be configured and controlled using this connection. That enables the Charge Station to be always connected by wire with the backend, Smart Meter, or even EMS.

Connecting this feature is optional. If you are not connecting an ethernet cable, continue with the next chapter.

1. Choose an entry position for the ethernet cable and follow applicable codes and regulations for routing the cable. Webasto recommends using the left floor-facing housing entry position (NPT $\frac{3}{4}$ inch) for grid wiring and the right floor-facing entry position for ethernet cable routing, see Fig. 14.
2. Feed the ethernet cable through the back connection or conduit into the Charge Station. Make sure the cable is equipped with an RJ45 connector. Make sure that the enclosure protection class (NEMA 4) is maintained when using an ethernet cable by using appropriate conduits and fittings.
3. Plug the cable with the RJ45 connector into the RJ45 socket. Route the ethernet cable in such a way that it is above the HMI cable (this is a pre-installed flat ribbon cable). Next, secure the cable position on the HMI board holder using the supplied cable tie as shown in Fig. 15.
4. Attach the ferrite in the required position as shown in Fig. 16.

**NOTE**

Choose an appropriate ethernet cable that meets all applicable state, local, and national electrical codes, and standards. Minimum ethernet cable requirements:

- Type CAT 6a
- S-FTP shielding type
- Minimum bend radius ≤ 1.2 inches (30 mm)
- Diameter 0.28–0.33 inch (7–8.5 mm)
- Straight RJ45 Plug

**WARNING**

The ethernet port shall be free of tension during and after cable installation.

**WARNING**

For the ethernet cable entry choose appropriate installation materials, such as conduits or cable grommets, so that the ingress protection class of the enclosure is maintained after the ethernet cable installation.

**CAUTION**

Mount the conduit or cable gland in accordance with all applicable state, local, and national electrical codes, and standards. Make sure that the enclosure type rating (NEMA 4) is maintained after the conduit and the ethernet cable have been installed. Verify that conduit entry accessories, such as blind plugs and cable glands, etc. have been fitted properly. This also applies to sealing rings.

**CAUTION**

Gently plug the cable into the RJ45 jack. Take care not to bend the PCBA by applying too much pressure when mounting.

**WARNING**

Make sure that the ethernet cable is routed such that there is sufficient clearance between the ethernet cable and all parts of the PCBA as well as enough distance from other current-carrying wires.

**WARNING**

When routing the ethernet cable make sure that distance to other current carrying parts meet local codes and regulations. If necessary, use additional isolating materials (e.g. heat shrink tube) to meet isolation requirements between ethernet data signal wires, PCBAs, and power wires.

**WARNING**

To avoid unexpected behavior, EMC snap ferrite must be applied on the LAN cable according to installation instructions.

7.5.9 Set the DIP switches

Set the DIP switches as explained in chapter 7.4.1, "DIP switch settings" on page 11 according to the installed setup and environment.

The location of the DIP switches is shown in Fig. 10 and marked as interface A.

Fold down the HMI holder as shown in Fig. 17 to finish the wiring process.

**DANGER****High voltages**

The danger of fatal electric shock. Ensure safe isolation from the power supply.

**NOTE**

Folding down the HMI to the operating position is mandatory to continue with the installation process.

7.5.10 Mount front cover

- Before mounting the front cover on the enclosure base, please check again:
 - The correct and tight connection of the grid wires in the terminal.
 - The correct and tight connection of the charging cable wires in the terminal.
 - The correct connection of the CP line.
 - The correct DIP-switch settings.
 - The correct position and mounting of the charging cable and the cable clamp.
 - If ethernet cable is used: The correct routing and fixation of the ethernet cable and the ferrite.
- Place the front cover on the housing.
- Use a Torx T20 screwdriver and ten screws ($\frac{5}{32} \times \frac{5}{8}$ inch (4 x 16 mm)) to tightly mount the front cover (torque setting: 5 Nm / 44.3 in-lbs.). Crosswise tighten the screws to the final torque value. See Fig. 18.

**WARNING**

Make sure that the front cover seal is correctly seated in the sealing groove and has not been damaged. Do not use the unit if the sealing has been damaged or has not been fully placed into the groove. When mounting the front cover onto the housing, make sure that the HMI ribbon cable is placed fully inside the enclosure, and that the cable cannot get pinched between the housing and front cover during assembly.

7.5.11 Prepare design cover

If you want a floor-facing cable entry position, then carefully break out the correct knock-out segment for cable entrance in the trim cover using pliers or a similar tool. See Fig. 19. For best results, turn the design cover on its back, take a pair of pliers and place them on the outermost edge, as shown in the image below, and then press down carefully. With a round file, smooth any rough edges after having removed the knock-out.

**CAUTION**

Wear protective gloves and safety glasses when breaking out the cable entry area at the predefined position to avoid injury by edges or burrs.

7.5.12 Mount design cover onto the housing

Clip the design cover onto the enclosure. When properly seated, its parts will visibly and audibly snap on. See Fig. 20.

7.5.13 Install remote dock**NOTE**

It is recommended to mount the dock holder so that the lowest point of the vehicle connector is between 20 inches (500 mm) and 59 inches (1500 mm) above floor level when stored.

**NOTE**

You must make sure that the drill holes are at least 4 inches (100 mm) deep.

- Take the mount dock rear holder out of the box.
- Mark the drill holes by using the rear part of the dock holder as a template.
- Drill two holes ($\frac{5}{16}$ inch / 8 mm) in the marked positions.
- Push the two dowels ($\frac{5}{16} \times 2$ inch / 8 x 50 mm) firmly into the drill holes.
- Use a Torx T20 screwdriver and two screws ($\frac{1}{4} \times 3.5$ inch / 6 x 90 mm) to mount the dock's rear holder on the wall. See Fig. 21.
- Carefully clip the dock front cover onto the dock's rear holder. See Fig. 22.
- To mount the dock, insert it onto the dock's front cover, use two screws ($1\frac{3}{64} \times 1\frac{5}{32}$ inch / 5 x 12 mm) and a Torx T25 screwdriver (torque: 1.8 Nm / 15.9 in-lbs). See Fig. 23.

7.6 Apply Scan & Charge QR code

The TurboConnect Charge Station is now fully installed (Fig. 24). The application of the peel-off Scan & Charge QR code sticker is optional.

- Peel off the sticker for "Scan & Charge"
- Place the sticker wherever you like on the design cover or holster.

7.7 Preparing to set up the Charge Station

Download the Setup App and WCC App as described in chapter 7.2, "Digital installation and user apps" on page 10.

- Download the Webasto Charger Setup App (for installation).
- Download the Webasto ChargeConnect App (for operation) and create a user account (if not available).
- Locate your Label Information of the charge station (see page 3). The Label contains the charge station ID, Master Password, Hotspot SSID & Password.
- Make sure that you have a sufficient Wi-Fi signal at the charge station location (for the network that you want to run the charge station on).

7.8 Initial start-up**7.8.1 Safety check**

Document the results of the checks and measurements carried out during the initial start-up corresponding to the applicable installation requirements and standards.

The Webasto Charger Setup App supports you with checks during the initial start-up.

The local regulations relating to the operation, installation, and environmental protection also apply.

7.8.2 Start-up procedure

- Switch on the power supply.
- Start the Webasto Charger Setup App.
- Select Scan QR Code from the Quick Start Guide or put in SSID and Wi-Fi key.
- Follow the in-app instructions to complete the setup.
- Locate, and connect to your Wi-Fi network for backend connection.

7.8.3 First Operation with Webasto Charge Connect App

To use the Webasto ChargeConnect App the charge station must be set up with internet and backend connection.

- Turn on Wi-Fi on your smartphone.
- Start the Webasto Charge Connect App.
- Select the menu for adding a new charge station and follow the instructions.

After the charge station's registration and pairing with the backend account, it is ready to be managed by the Webasto Charge Connect service.

8 WebUI

The WebUI is a graphical user interface that a user can use to interact with the system via a web browser.

The WebUI can be accessed in the browser in the following ways:

1. With a WLAN / Wifi connection to the hotspot in the wall box, the WebUI can be accessed in the browser at the following IP address: 172.20.0.1
2. With a WLAN / Wifi or LAN connection to the router, the WebUI can be accessed in the browser at the following IP addresses:
 - YYYYY (YYYYY --> IP address that has been assigned to the wall box by the router)

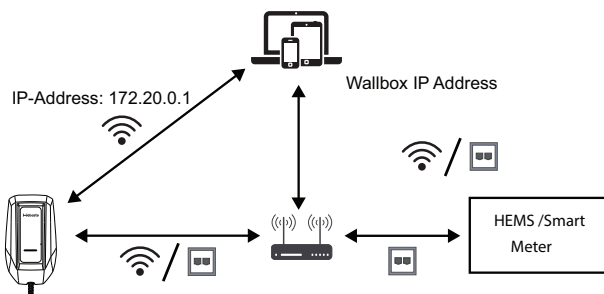

Login data:

User name: admin

Password: master password (see installation documentation)

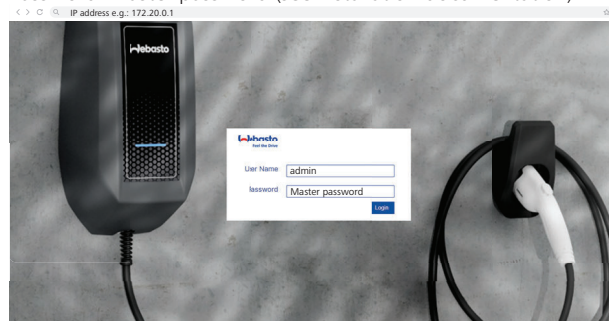

8.1 Settings in the WebUI for DLM

The configuration of the DLM in the WebUI will be described below. For more information see chapter 9, "Dynamic Load management – Stand-alone mode (DLM)" on page 17.

1. Select the HEMS (Home Energy Management System) tab in the WebUI.

2. Enable expert mode.
3. Under Mode, select "DLM with external meter activated".
4. Under Connection type select "LAN" or "WLAN" (Wifi).
5. Under "Safe current L1" select the maximum possible current when there is no connection to the smart meter.



NOTE

Set "Safe current" L2 and L3 to 0.

6. Under External Meter IP enter the IP address for the meter assigned by the router.
7. Under External Meter Module select the meter model.
8. Under External Meter Position select "including wallbox" or "excluding wallbox".
9. Under Recalculation interval enter 30.
10. Under "Current limit external meter L1" enter the maximum current.



NOTE

Set "Current limit external meter" L2 and L3 to 0.

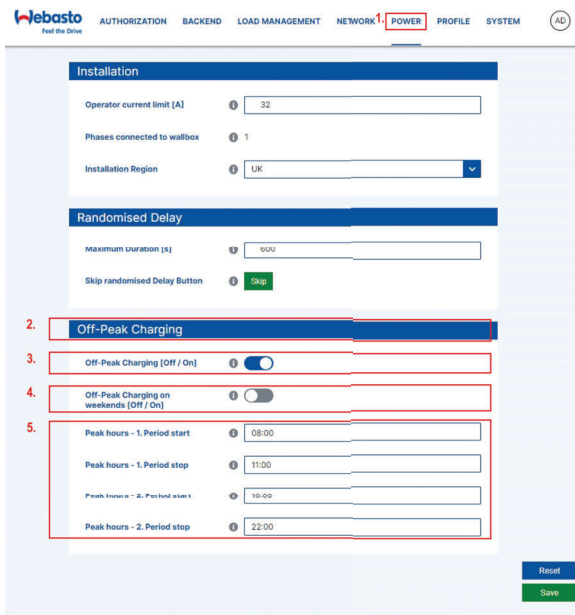

8.2 Setting in the WebUI for HEMS

The configuration of the HEMS in the WebUI will be described in the following chapter. For more information see chapter 10, "Home Energy Management System (HEMS)" on page 17.

1. Select the HEMS tab in the WebUI.
2. Enable expert mode.
3. Under Mode select HEMS activated.
4. Under Connection type select LAN or WLAN / Wifi.
5. Under "Safe current L1" select the maximum possible current when there is no connection to the smart meter.



NOTE

Set "Safe current" L2 and L3 to 0.

6. Under Recalculation interval enter '30'.
7. Under "Current limit external meter L1" enter the maximum current.



NOTE

Set "Current limit external meter" L2 and L3 to 0.

8. Then apply the settings in the EMS system.

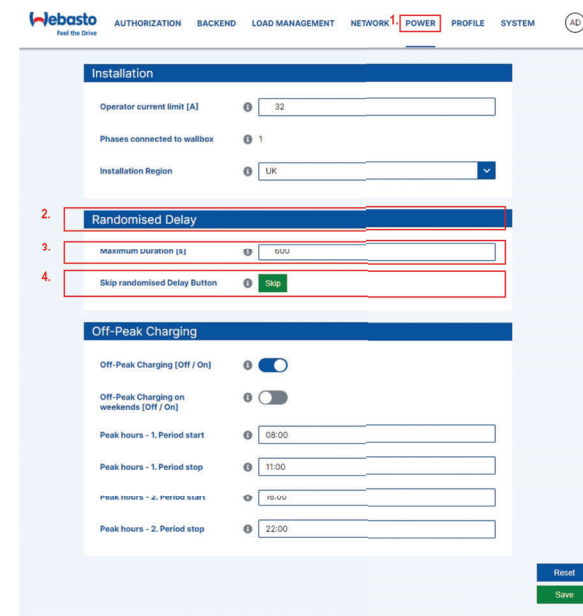

9 Dynamic Load management – Stand-alone mode (DLM)

The TurboConnect Charge Station has a local, dynamic load management stand-alone function. Here, one smart meter per Charge station is connected to the wall box via a router or DHCP switch.

This communication makes use of the Modbus TCP protocol via the RJ45 port. A connection between the wall box and router can also be made using Wi-Fi, but this setup is not recommended when using a smart meter on account of the potentially unstable connection.

A list of compatible smart meters can be found at <https://www.evsolutions.com/ev-charging-product-resources>. The DLM communication protocol for the TurboConnect Charge Station can be enabled in the Setup app <https://www.evsolutions.com/ev-charging-product-resources> or via the integrated WebUI chapter 8, "WebUI" on page 16. Alternatively, the TurboConnect Charge Station can be connected to the smart meter directly using an Ethernet cable. However, this type of connection is not recommended as both devices require a static IP address.



NOTE

Assign a static IP address to all Webasto TurboConnect Charge Stations using the settings on your Internet router.

There are two possible locations for the smart meter in the house:

1. Smart meter is located at the hub of the central electricity grid panel.

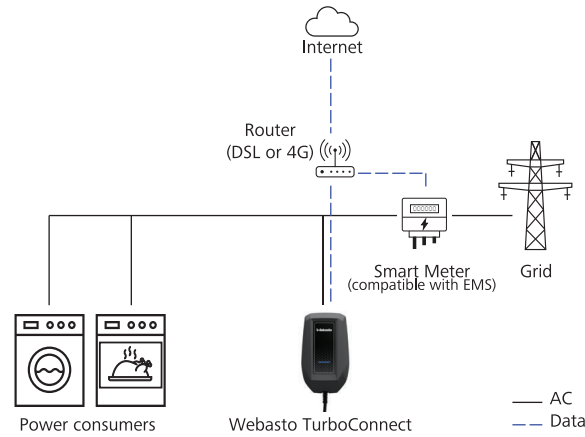

2. Smart meter is located after Charge Station in the dedicated circuit.

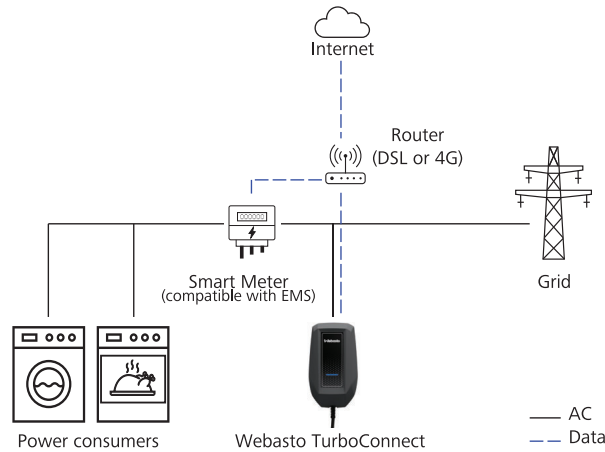

10 Home Energy Management System (HEMS)

The TurboConnect Charge Station can be integrated into a range of energy management systems (EMS). Here, the external EMS module is connected to the wall box via a router or DHCP switch. This communication makes use of the Modbus TCP protocol via the RJ45 port. A connection between the wall box and router can also be made using Wi-Fi, but this setup is not recommended when using an EMS system on account of the potentially unstable connection.

A list of compatible EMS modules can be found at <https://www.evsolutions.com/ev-charging-product-resources>. Depending on the EMS selected, functions such as photovoltaics (PV) excess charge or dynamic load management with multiple wall boxes (cluster) are possible. The EMS communication protocol for the Webasto TurboConnect Charge Station can be enabled in the Setup app <https://www.evsolutions.com/ev-charging-product-resources> or via the integrated WebUI chapter 8, "WebUI" on page 16. Alternatively, the TurboConnect Charge Station can be connected to the EMS module directly using an Ethernet cable. However, this type of connection is not recommended as both devices require a static IP address.



NOTE

Assign a static IP address to all Webasto TurboConnect Charge Stations using the settings on your Internet router.

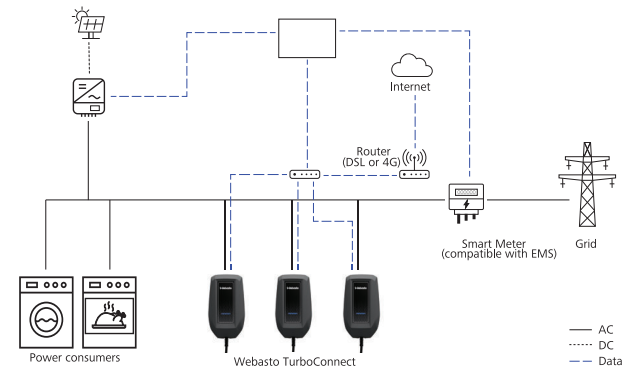

11 Charge Station Dimensions

See Fig. 29.

12 Settings



NOTE

You can adjust the settings of your Webasto TurboConnect Charge Station using the following options.

For installation:

- Webasto Charger Setup app

For operation and setting:

- Webasto ChargeConnect portal
- Webasto ChargeConnect app
- Integrated WebUI (configuration interface, see chapter 8, "WebUI" on page 16)

13 Operation

13.1 LED and acoustic indicators

State	Status Indicator	Description	Explanation
Unpowered		Off	The charge station is not powered.
Power On		Blue, center single LED, solid	The charge station is powered, and the "free charging" mode is ON (default state).
Standby		Blue, full bar, solid	The charge station is receiving power and is ready to charge the vehicle.
Charging		Blue, full bar, pulsing	The charge station is successfully charging the vehicle.
Locked		Blue, center single LED, intermittent	The charge station is powered, and the "free charging" mode is OFF. The charge station will not charge until authorization or setting the "free charging" mode to ON.

State	Status Indicator	Description	Explanation
Plugging In		White, full bar, cycling to middle	The charge station is connecting to the vehicle, preparing to charge.
Update / Rebooting		White, wipe left to right	The charge station is downloading firmware or rebooting after changes to settings.
SelfCheck mode		White, full bar, solid	The charge station is checking that all status indicators are working.
Charging Reduced (Overheating)		Amber, full bar, solid background. Blue, center, pulsing	The charge station is charging at a reduced rate due to overheating.
Station Error State		Amber, full bar, solid	The charge station has a fault and requires troubleshooting.
Station fault		Red, full bar, solid	The charge station has experienced a non-recoverable fault.
Station Electrical fault		Red, full bar, blink	The charge station has experienced a ground fault.
Unplug		White, full bar, fade out	The charge station is being disconnected from the vehicle (a few seconds).

Table 4: Information on Status indicators



NOTE

In case of a ground fault, additionally, an acoustic buzzer signal will occur.



NOTE

A temporarily incorrect HMI state is not an indication of a defect or faulty condition of the TurboConnect Charge Station. It does not affect the functions. If the incorrect HMI state occurs repeatedly, the surrounding environment of the TurboConnect Charge Station must be checked for interfering wireless devices / installations and they must be eliminated. If that is not possible, select another installation location for the TurboConnect Charge Station with no disturbances. A dedicated circuit for this installation is recommended.

13.2 Start Charging

To start a typical charging session:

1. If the charge station is locked, unlock the charge station (see Table 4, "Information on Status indicators" on page 18).
2. Open the vehicle charging port cover.
3. Remove the coupler from the remote dock.
4. Plug the coupler into the vehicle charging port until it clicks. The charge station should indicate that the vehicle is establishing a connection to the charge station. The charging cable must not be subjected to any strain during use as shown in Fig. 27.
5. As soon as the vehicle and charge station are connected, the charge station indicator exhibits one of the following states:
 - The charge station will be on standby if the vehicle is fully charged or scheduled to charge later.
 - The charge station will begin charging.



NOTE

A shutdown, or a reduction in charging current, may occur to prevent the charge station from overheating. This is a safety feature.

13.3 Stop Charging

You will generally end a charging session when charging is complete (indicated by the charge station status indicator being in a standby state), but you can also interrupt and end an incomplete charging session.

To stop a charging session:

1. Unlock and remove the coupler from the vehicle by pressing the coupler button. The charge station should return to Power On state.
2. Close the vehicle charging port cover.
3. Wrap the loose cable around the remote dock.
4. Plug the coupler into the remote dock.
5. Lock the charge station if desired.

13.4 Scan & Charge locking function

You can enable or disable the charge station locking function in the Webasto Setup app or the WebUI. If you want to restrict access to the charge station for other users, disable "free charging" in the Webasto Setup App. The Webasto ChargeConnect App then offers the option of enabling individual charging processes via the supplied Scan & Charge QR codes, which are in the scope of delivery. Instructions for charging in the locked state:

1. Connect the TurboConnect charging cable to the charging port on your vehicle. In the locked state, a charging process will not yet take place. The charge station shows a blue-blinking single LED light.
2. Scan one of the supplied Scan & Charge QR codes using the corresponding function in the Webasto ChargeConnect app. The charging process will be enabled and will start. The charge station shows a pulsing blue light.
3. After unplugging the charging cable at the end of the charging process, free use is locked once more. For a further charging process, repeat the steps.

 **NOTE**
 Printing out additional Scan & Charge QR codes If you need additional Scan & Charge QR codes, you can print these out as described in chapter 4.1, "Printing additional "Scan & Charge" QR codes" on page 9.

 **NOTE**
 Storing QR codes You can keep your QR codes in your wallet or in the entrance area of your home to enable charging processes in the locked state.

For more details see the Webasto ChargeConnect App (see chapter 7, "Installation and electrical connection" on page 10).

14 Troubleshooting

HMI state	Recommended actions
Unpowered	Make sure that the circuit is operational and that the circuit breaker is switched on. If the problem persists, please contact Customer Service.
Not Charging	<ol style="list-style-type: none"> 1. Make sure that the charge station is not in a locked state. 2. Use the circuit breaker to turn the power OFF. Turn the power ON and wait 5 minutes. Disconnect the charging coupler during the reset. 3. Make sure that the vehicle coupler is properly inserted into the vehicle. 4. Verify and adjust your vehicle charge scheduling or time preferences. 5. Verify that the vehicle is not fully charged already.

HMI state	Recommended actions
Unexpected standby	<ol style="list-style-type: none"> 1. Make sure that the vehicle coupler is properly inserted into the vehicle. 2. Verify and adjust your vehicle charge scheduling or time preferences. 3. Verify that the vehicle is not fully charged already.
Update / Rebooting	Wait for the charge station to finish its updates.  NOTE Unplug the vehicle coupler before cycling the breaker off and back on. Then plug the vehicle coupler back into the vehicle. If the issue persists, please contact Customer Service.
Charging reduced	<ol style="list-style-type: none"> 1. Wait for the charge station to cool down. 2. Try to move the charge station to a cooler area or try to avoid exposure to direct sunlight. 3. If the issue persists, please contact Customer Service.
General troubleshooting	<ol style="list-style-type: none"> 1. Unplug the charge station from the vehicle. 2. Switch the charge station off and back on at the circuit breaker. 3. If the issue persists, please contact Customer Service.
Non-recoverable fault	To prevent having to replace the charge station unnecessarily, evaluate the error code shown on the Webasto ChargeConnect App. For example, if there is a ground-monitoring. If the issue persists, please contact Customer Service.
Ground leakage fault	<ol style="list-style-type: none"> 1. Unplug the coupler from the vehicle. 2. Switch off the circuit breaker. 3. If the issue persists, please contact Customer Service.
Locked	Use "Scan & Charge" to authorize or set "Free Charging" to OFF for permanently unlocking the charge station.
Setup mode stopped	<ol style="list-style-type: none"> 1. Make sure the Wi-Fi signal at the charge station location is strong. 2. Switch the modem and router off and back on, and then reconnect to the Wi-Fi network. 3. Restart the setup process. 4. Unplug the charge station from the vehicle.

HMI state	Recommended actions
App lost communication	<ol style="list-style-type: none"> 1. Make sure the Wi-Fi signal at the charge station location is strong. 2. Switch the modem and router off and back on, and then reconnect to the Wi-Fi network. 3. Close and restart the Webasto ChargeConnect app. 4. If a user who has been invited by the owner has lost connection, then verify the user's access status.
Self-Check mode	If this mode persists for more than a few minutes: <ol style="list-style-type: none"> 1. Unplug the charge station from the vehicle. 2. Switch the charge station off and back on at the circuit breaker. 3. If the issue persists, please contact Customer Service.

Table 5: Issues and recommended actions

 **NOTE**
 If the issue persists after troubleshooting and following the instructions offered in the app, then please contact Customer Service.

 **NOTE**
 In case there is no app Message, unplug the vehicle coupler, and cycle the circuit breaker off and back on. The TurboConnect Charge Station will indicate Power on Status (blue center LED) after two minutes. After this, you can plug the coupler and proceed with normal operation. If after 3 trials the error persists, unplug the vehicle coupler, and contact customer service.

15 Decommissioning the product

Decommissioning shall be carried out only by a qualified electrician.

1. Switch off the power supply and vehicle charging line.
2. Electrically disconnect the charge station and make sure that open and hot connections are not accessible.
3. Remove all connection lines and communication lines.
4. Dispose of the TurboConnect Charge Station in accordance with local and national rules and regulations.

16 Maintenance, cleaning, repair

16.1 Maintenance

Maintenance must be carried out by an electrician only, and in accordance with local requirements.

16.2 Cleaning



DANGER **High voltages**

The danger of fatal electric shock. Do not clean the charge station with running water.

The TurboConnect Charge Station does not require any routine maintenance other than periodic cleaning as described below. Clean the TurboConnect Charge Station only with a dry cloth. Do not use aggressive cleaning agents, wax, or solvents. Do not open the device for cleaning purposes.

16.3 Repair

Unauthorized repair of the charge station is not permitted. Webasto reserves the exclusive right to perform repairs to the charge station. It is only permitted for repairs to be carried out by an electrician using original spare parts sold by Webasto.

17 Replacement of the charging cable



DANGER **The danger of fatal electric shock**

Switch off and secure the power supply to the charge station.



NOTE
Only use genuine Webasto parts of the same power level.



NOTE
The charging cable may be replaced a maximum of four times during the service lifetime of the TurboConnect Charge Station.



NOTE
If you require spare parts, please contact your installer or dealer.

18 Disposal

The TurboConnect Charge Station is an electronic device that may not be disposed of as part of unsorted waste. Dispose of the product in accordance with local and national regulations.

19 Declaration of Conformity

Webasto Charging Systems Inc. declares that the EVSE "TurboConnect" complies with the following standards and regulations:

- ANSI/UL2594
- CAN/CSA-C22.2 No.280-16
- UL2231-1, UL2231-2
- CAN/CSA-C22.2 No 281.1 and No.281.2
- FCC Part 15, Subpart B and C
- ICES-003
- RSS-GEN, RSS-247
- NEC Article 625 compliant

The TurboConnect Charge Station was developed, manufactured, tested, and supplied in accordance with the above-mentioned standards and regulations, and in accordance with the relevant standards for safety, electromagnetic compatibility (EMC), and environmental compatibility. The TurboConnect Charge Station is certified and listed by Intertek's ETL certification program. The TurboConnect Charge Station is Energy Star certified.

20 Federal Communications Commission (FCC) statement



NOTE

This equipment has been tested and found to comply with the limits for a Class B digital device, pursuant to part 15 of the FCC Rules. These limits are designed to provide reasonable protection against harmful interference in a residential installation. This equipment generates, uses, and can radiate radio frequency energy and, if not installed and used in accordance with the instructions, may cause harmful interference to radio communications. However, there is no guarantee that interference will not occur in a particular installation. If this equipment does cause harmful interference to radio or television reception, which can be determined by turning the equipment off and on, the user is encouraged to try to correct the interference by one or more of the following measures:

- Reorient or relocate the receiving antenna.
- Increase the separation between the equipment and receiver.
- Connect the equipment to an outlet on a circuit different from that to which the receiver is connected.
- Consult the dealer or an experienced radio / TV technician for help.

21 Legal Notice



NOTE

The content of this document is based on the latest information available at the time of printing.

Webasto Charging Systems Inc. reserves the right to make changes to this document at any time without further notice. While the information in the document has been carefully checked for accuracy, no guarantee is given for the completeness and correctness of the contents, including but not limited to the product specifications, functions, and illustrations. Any resulting damage due to disregard or actions contrary to the instructions in this manual is excluded from the product warranty.

22 Technical data

Electrical	Station characteristics
Nominal current (RMS) (configurable connected load values)	48 A
Line voltage (VAC) (nominal)	240 V / 208 V (Line-to-Line voltage)
Grid frequency (Hz) (nominal)	60 Hz
Overvoltage category	III
Protection class	I
Integrated power meter	Accuracy +/- 5%
Connections	
Cable feed	Mounted on-wall, or in-wall
Connection cross-section output (Wire dimension charging cable)	2x 6 AWG (L1/L2) 1x 8 AWG (GND) for the charging cable only (observe local codes / regulations)
Charging cable (including coupler)	Charging cable with Type 1 coupler according to SAE J1772 Cable length 20 ft / approximately 6 m
Output voltage (V AC)	240 V / 208 V
Maximum charging capacity (kW)	11.5 kW
Connection cross-section input (Wire dimension grid)	Power input cable L1 / L2 / PE cross-section up to 2 AWG (35 mm ²). Follow local and national codes and regulations for dimensioning.
Communication & features	
Vehicle-charger Communication Protocol (CP)	SAE J1772
Authentication	Wi-Fi Hotspot
Display	9 RGB-LEDs
Network interface (wired)	Ethernet / LAN, IEEE 802.3u – 100BASE-TX, RJ-45 port
Network interface (wireless)	Wi-Fi IEEE 802.11 a/b/g/n – up to 150 Mbit/s
Authentication and mobile communications	Wi-Fi -Webasto Charger Setup-App
OCPP	Version 1.6j
Mechanical data	
Dimensions (W x H x D)	10.2 x 17.7 x 5.5 Inches / 258 x 450 x 141 mm
Weight (including wall mount bracket & charging cable)	17.53 lbs. 7.95 kg
Recommended installation height	Minimally 35 inches (900 mm) above floor level (to the bottom of the device).
Enclosure protection class Type 4 per UL50E (NEMA 4)	NEMA 4
Protection against mechanical impact	ANSI/UL2594
Ambient conditions	
Operating temperature range	-40°F to +122°F / -40°C to +50°C
Storage temperature range (°C)	-40°F to +185°F / -40°C to +85°C
Altitude (m)	Max. 9,842 ft (3,000 m) above sea level

Electrical	Station characteristics
Certification compatibility	
Other standards and guidelines	<ul style="list-style-type: none"> - ANSI/UL2594 - CAN/CSA-C22.2 No.280-16 - UL2231-1, UL2231-2 - CAN/CSA-C22.2 No 281.1 and No.281.2 - FCC Part 15, Subpart B and C - ICES-003 - RSS-GEN, RSS-247 - NEC Article 625 compliant
Tested with OCPP backend(s)	Webasto Charge Connect OCPP (Open Charge Point Protocol) backend

Table 6: Technical data

23 Checklist for the installation of the Webasto charge station

Please complete the TurboConnect Charge Station commissioning report.

Serial number:	
Material number:	
Voltage	240 V (residential split phase) 208 V (industrial)
General preconditions:	
Installation, electrical connection, and initial operation of the charge station have been carried out by a qualified electrician.	<input type="checkbox"/>
The charge station has been inspected for visual damage before installation and use.	<input type="checkbox"/>
Local installation conditions:	
The charge station has not been installed in an explosion-sensitive area (Ex Zone).	<input type="checkbox"/>
To achieve optimal performance of the charge station, areas with direct sunlight have been avoided.	<input type="checkbox"/>
The charge station has been installed in a location where falling objects cannot damage the charge station.	<input type="checkbox"/>
The location of the charge station has been selected in such a way that vehicles cannot inadvertently collide with it.	<input type="checkbox"/>
The legal requirements for electrical installations, fire protection, safety regulations, and escape routes have been met.	<input type="checkbox"/>
Ensure that the EVSE is installed in a dedicated supply circuit with a non-GFCI two-pole circuit breaker, in accordance with local codes and ordinances.	<input type="checkbox"/>
The charging cable does not obstruct any passageways.	<input type="checkbox"/>
The charging cable and coupling have been protected against coming into contact with external heat sources, water, dirt, and chemicals.	<input type="checkbox"/>
The charging cable and coupling have been protected against being driven over, trapped, or any other mechanical hazards.	<input type="checkbox"/>
Charge station installation requirements:	
Tools and installation materials have been removed from the charge station before closing the cover.	<input type="checkbox"/>
A suitable charging cable (single phase) has been installed in the charge station (as per the type label) during installation.	<input type="checkbox"/>
The charging cable has been connected as per installation instructions.	<input type="checkbox"/>
The customer has been instructed on how to use the charge station correctly.	<input type="checkbox"/>
The installer has checked the correct operation of the charge station using an EV simulator / tester.	<input type="checkbox"/>
Customer / client:	Date
Electrician / contractor:	Date

To request this documentation in another language, please locate and contact your local Webasto dealer. You can find your nearest dealer at: <https://www.evsolutions.com/>.

To provide feedback (in English or German), please email: feedback2tdt@webasto.com.

Webasto Customer Service:
+1 (888) 833-2148

evcs@webasto.com

Webasto Charging Systems Inc.

1960 Walker Ave
Monrovia, CA 91016
USA

www.webasto.com

